

# Smart-Clip

## USER'S MANUAL

---

*Smart-Clip is a professional device that removes SP/SIM/phone/user lock.*

*Smart-Clip works with a wide range of mobile phone models  
(see latest list at [http://www.smart-clip.com/index\\_models.html](http://www.smart-clip.com/index_models.html)).*

*Simple standalone one-button operation.*

*Unlocking with Smart-Clip takes just a couple of seconds.*

*No PC, disassembling or special technical knowledge needed.*

### OUTSTANDING FEATURES

- Standalone operation
- Large list of Smart-Clip supported phone models (all versions), constantly growing
- Real-time upgrades online
- Free Motorola upgrades (A, C, E, T, V series)
- Phone flash reading using Smart-Clip Reader

### UPGRADES

Smart-Clip uses LPT port to connect to PC.

Smart-Clip firmware can be upgraded through the Internet in real-time using our ActiveX plugin.

Upgrades include latest firmware AND additional phone vendors/models support.  
(NOTE: Motorola upgrades are FREE OF CHARGE)

### FEATURES CURRENTLY IN DEVELOPMENT

- Direct special function to repair phones using full flashing
- Direct JTAG function to repair phones with lost boot zone
- Direct JTAG function for testing CPU/RAM/FLASH

Features listed above will be available via upgrades free of charge for Motorola

## OPERATION INSTRUCTION

1. Power on the Smart-Clip and E/G indicator will light green.
2. Power on the phone without SIM card and flash card (if present).
3. Connect phone to Smart-Clip and press the red button.
4. E/G indicator will light green and go off, the phone will switch off (some models will automatically turn on then).
5. E/G will light green on success or red on error

## UNLOCK PROCEDURE FOR MOTOROLA A920/A925:

1. Power the phone on.
2. Connect the phone to a powered clip. Phone display should give "USB cable connected" message.
3. Press UNLOCK button on the clip.
4. Phone reloads. Within 5-10 seconds phone display gives "Waiting for PST" message.
5. Press A and B keys simultaneously in upper part of the handset. The phone enters boot mode (if you don't press these 2 keys during "Waiting for PST" message, the clip will give red E/G led and you'll have to start with step 1).
6. After A and B keys have been pressed E/G green led will blink and phone reboots. Meanwhile E/G will give frequent green blinking and phone will turn on. **Don't disconnect phone from Smart-Clip while green led indicator blinks!**
7. Green E/G led glows. The phone is unlocked.



## MOTOROLA A835/A845/E396/E398/V80 UNLOCKING NOTE:

Don't unplug cable right after phone reboot, wait until E/G led stops blinking!

## MOTOROLA E396/E398 UNLOCKING NOTE:

Remove flash card from phone before unlocking

## MOTOROLA C115/C116/E365 UNLOCK PROCEDURE:

1. Power off the phone
2. Connect clip to the phone
3. Press UNLOCK button
4. Press Power button on the phone within 5 seconds after you press UNLOCK button on a clip. RX/TX leds will blink
5. E/G led will glow green on success.

C115 cable pinout:

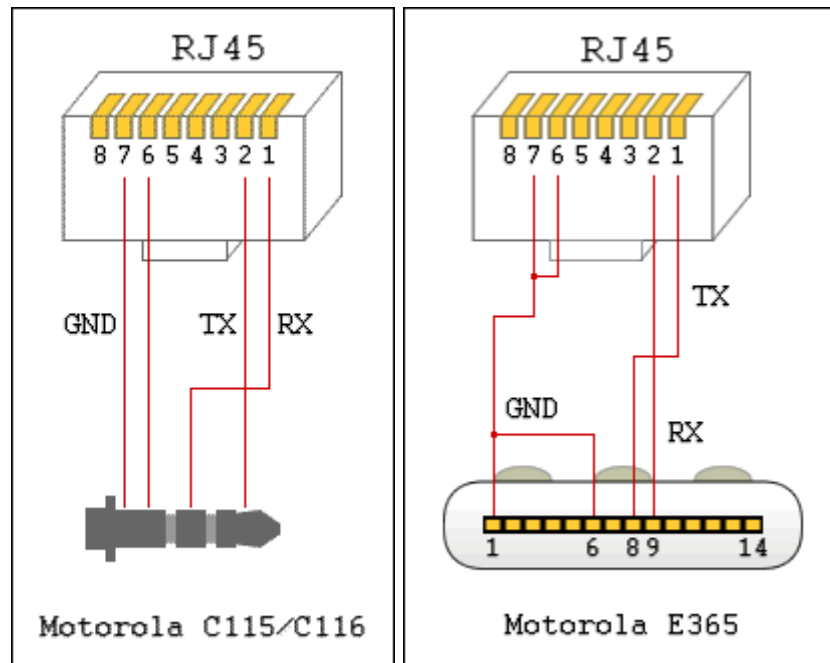

## SMART-CLIP UPGRADE PROCEDURE

1. Connect Smart-Clip to PC using LPT cable
2. Power Smart-Clip ON (warning: don't use battery!)
3. Go to our [Upgrade Zone](#)
4. Upgrade Zone uses ActiveX element, answer "Yes" to install and run it
5. Press "Connect"
6. Press "Update" if your version is out of date
7. Power Smart-Clip OFF
8. Disconnect LPT cable

## USING SMART-CLIP READER (SCReader.exe)

1. Connect Smart-Clip to PC using LPT cable
2. Power Smart-Clip ON (warning: don't use battery!)
3. Run SCReader.exe (WinXP/2k with admin rights)
4. Press "Connect"
5. Press "Read history", save to file
6. Press "Read flash", save to file
7. Close Smart-Clip Reader
8. Power Smart-Clip OFF
9. Disconnect LPT cable

10. Send history and phone flash files to [support@smart-clip.com](mailto:support@smart-clip.com)

## TROUBLESHOOTING

If you have any trouble upgrading your clip, please check the following requirements:

- firewall on your computer is disabled or configured properly
- you have reliable internet connection
- LPT port settings are set to EPP in BIOS
- you use a stable power supply (adapter) with your clip
- your Internet Explorer version is not lower than v5.0
- if you use Win XP, log in as administrator

If you have problems updating under Win XP please download Porttalk file, unzip it and run `install.bat` file. After it reboot your computer.

If you have problems with update make a screenshot of update report and email immediately to [support@smart-clip.com](mailto:support@smart-clip.com)

## FAQ

### Does Smart-Clip need to be activated?

No. It does not need to be activated. This product is developed in a ready to go fashion. However, it may happen that by the time you have Smart-Clip there is a newer version of firmware available for it. You can update your clip easily by going to <http://www.smart-clip.com/upgrade.php> and running "Smart-Clip Online Updater".

### Where do I get login/password for product update?

Smart-Clip update system is organized in such way that you do not need to register for update. Every owner can go to support page and connect his/her clip using "Smart-Clip Online Updater". It is free and open to everyone.

### How do I know the version of my Smart-Clip?

You can go to upgrade zone on our site and connect smart-clip using . When the program asks you if you want to install and run "Smart-Clip Online Updater" answer "yes". Update program will inform you about your product version.

### Why is there LPT port in Smart-Clip?

Smart-Clip is not a final solution. Rather it is a platform for ongoing solutions constantly developed by GsmServer team. Similar to Griffin and Twister Smart-Clip stays efficient all the time by means of available updates. LPT port is a physical channel for on-line updates.

### Do I need to configure my LPT port for Smart-Clip update?

Normally all LPT ports are set by default to operate in Smart-Clip friendly way. However, if your LPT configurations have been changed you should know that

bidirectional modes (EPP, ECP) are required for Smart-Clip update to operate properly.

#### **How do I update my Smart-Clip?**

Please go to page <http://www.smart-clip.com/support.html> for instructions.

#### **"Smart-Clip Online Updater" doesn't show in my browser. What do I do?**

In order to install and run "Smart-Clip Online Updater" you need to use Internet Explorer 5 and later IE versions. Your browser should be configured to allow Active X element use. This can be done in Internet options/Security Settings/Active X controls and plug-ins and check chapter.

#### **Why is there a service socket in Smart-Clip?**

This socket is installed for further implementation of future Smart-Clip features:

- Direct JTAG function to repair phones with lost boot zone
- Direct JTAG function for testing CPU/RAM/FLASH

#### **I went through all steps mentioned in Operation Instructions but E/G indicator stays red. Why?**

E/G indicator turns and stays red when there is an error. One of the reasons for it may be bad connection between Smart-Clip and computer.

#### **Power indicator blinks red. What does it mean?**

Most likely you are using Smart-Clip battery for power. The red light of power indicator shows low battery charge. Please replace battery and resume your work.

#### **What should I do if my Smart-Clip doesn't update?**

Should this happen, make a screenshot of update error and e-mail it to [info@smart-clip.com](mailto:info@smart-clip.com) . This will allow our support team to respond with solution quickly.

#### **Why do I need to send Smart-Clip history file with phone flash file?**

Smart-Clip logs are needed for developers to identify the potential capacity of Smart-Clip to unlock the specific phone model. Based on these logs they will work on developing necessary algorithms which will be added to Smart-Clip software and allow the clip to unlock the phone.

#### **I'm having problems when using Windows XP/2000...**

In order to successfully update your clip (or use SCReader.exe) under Windows XP you need to enter the system as an Administrator (or as a user with administrative rights).

#### **What should I do if Smart-Clip doesn't unlock a phone?**

First of all, make sure the phone model you are trying to unlock is in the list of supported models. If it is, you need to make sure the phone you are unlocking is charged to its full battery capacity and that battery connection poles are clean. Make sure your cable connection is good too. Use power adapter for Smart-Clip while unlocking. If your phone fails to unlock then read its firmware flash with Smart-Clip Reader and send it along with log file (history) to support[at]smart-clip.com

### Which LPT cable should I use for Smart-Clip update?

Please use 25 pin LPT cable with female and male endings to connect your clip to computer for the update.

### PACKAGE CONTENTS

- Smart-Clip device
- Cables for Motorola C, V series
- Battery connector

### TECHNICAL DATA

Dimensions (L x W x H)	86 x 66 x 32 mm
Net weight	136 g
Power	DC 9V, 50 mA
Phone cable type	USB
Construction	Aluminium casing

### WARRANTY

6 months (please note that cables are the accessories and are not covered by warranty)